



4060 Ridgeway Drive, Unit 7  
Mississauga, ON L5L 5X9

[www.bes.show](http://www.bes.show)  
[info@bes.show](mailto:info@bes.show)  
1.833.bes.show

# Bakery Showcase

May 5-6, 2024



welcome

## **Welcome to BAKERY SHOWCASE 2024!**

Bes Inc (Boneyard Event Services inc.) is pleased to have been appointed as the official General Service Contractor.

As your partner in exhibiting, it is our job to make you look good. Our goal to make every show hassle-free and enjoyable for you, the exhibitor.

Below, please find our products and services which are available for your event (If you don't see something you need, please contact our office to discuss):

- **Advance & Post-Show Warehousing**
- **Exhibit Labour**
- **System Booth Packages**
- **Carpets & Cleaning**
- **Tables & Drape**
- **Seating**
- **Counters, Plinths & Showcases**
- **Signage**
- **Transportation Services**

We look forward to being “Your Partner in Exhibiting”.

## **PAYMENT OPTIONS**

For your convenience we accept:

- **Cheques - MUST arrive at least one week prior to Move-In**
- **VISA, MasterCard or AMEX**
- **Interac e-transfers to [accounting@bes.show](mailto:accounting@bes.show) (please put show, company name, and booth number in message box)**
- **Wire Transfer - contact our office for banking details**

If you have any questions, please call our office at (833) BES SHOW (237-7469).

show: **BAKERY SHOWCASE 2024**  
 discount pricing deadline: **APRIL 12, 2024**

**IMPORTANT - this form MUST be completed if utilizing any services offered by BES Inc.**

Company:	Contact Name:	Booth #:
Address:	City:	Prov./State:
Postal Code:	Phone:	Fax:
Contact Email (required for receipt):		

**WIRE TRANSFER / ETRANSFER**

**COMPANY CHEQUE**  
 Please make cheque payable to **Boneyard Event Services Inc.**  
**NOTE: Cheques will not be accepted on show site**  
 ADDRESS: **BES Inc.**  
**7-4060 Ridgeway Drive**  
**Mississauga, Ontario**  
**L5L 5X9**

**CREDIT CARD**  
 BES Inc. will use this authorization to charge any outstanding fees upon show closing to the credit card listed below. These include funds related to any unpaid or outstanding balance due to BES Inc. - an NSF cheque, show site orders placed by your representative, material handling and advance shipment overages, installation and dismantle labour charge adjustments and transportation and customs brokerage service adjustments and post-show logistics.

**AMEX**       **MASTERCARD**       **VISA**

Card #: \_\_\_\_\_

Expiry Date: \_\_\_\_\_ CVV: \_\_\_\_\_

Cardholder's Name: \_\_\_\_\_

Signature: \_\_\_\_\_

Billing Address: \_\_\_\_\_

City/Province: \_\_\_\_\_ Postal Code: \_\_\_\_\_

**AUTHORIZATION**  
 We have read, understood and agree to all terms as described above and have advised our show site representative accordingly.

Exhibitor Signature: \_\_\_\_\_

Print Name: \_\_\_\_\_

Date: \_\_\_\_\_

**THIRD PARTY AUTHORIZATION**

FOR USE OF AN EXHIBITOR APPOINTED CONTRACTOR.  
 We understand and agree that we, the exhibiting firm, are ultimately responsible for payment of charges. In the event that the named third party does not discharge payment of the invoice prior to the last day of the show, charges will revert to the exhibiting company. All invoices are due and payable upon receipt, by either party. The items checked below are to be invoiced to the third party.

<input type="checkbox"/> ALL SERVICES	<input type="checkbox"/> RENTAL FURNITURE & CARPET
<input type="checkbox"/> BOOTH CLEANING (if applicable)	<input type="checkbox"/> SIGNAGE
<input type="checkbox"/> ELECTRICAL (if applicable)	<input type="checkbox"/> SYSTEM BOOTH PACKAGES
<input type="checkbox"/> I & D LABOUR	<input type="checkbox"/> ADVANCE/POST SHOW WHSE
<input type="checkbox"/> MATERIAL HANDLING / IN & OUT	<input type="checkbox"/> OTHER _____

THIRD PARTY AGENT:

Card #: \_\_\_\_\_

Expiry Date: \_\_\_\_\_ CVV: \_\_\_\_\_

Cardholder's Name: \_\_\_\_\_

Signature: \_\_\_\_\_

Billing Address: \_\_\_\_\_

City/Province: \_\_\_\_\_ Postal Code: \_\_\_\_\_

Phone: \_\_\_\_\_ Fax: \_\_\_\_\_

Email: \_\_\_\_\_

**CALCULATION OF ORDER**

ADVANCE / POST-SHOW WAREHOUSE	\$ _____
EXHIBIT LABOUR	\$ _____
SYSTEM BOOTH PACKAGES	\$ _____
CARPETS & CLEANING	\$ _____
SKIRTED TABLES & DRAPE	\$ _____
TABLES	\$ _____
SEATING	\$ _____
MISC	\$ _____
COUNTERS/PLINTHS/SHOWCASES	\$ _____
SIGNAGE	\$ _____
<b>TOTAL OF ITEMS:</b>	<b>\$ _____</b>
<b>13% HST</b> HST# 806143368 RT0001	<b>\$ _____</b>
<b>TOTAL ORDER</b> (CDN \$)	<b>\$ _____</b>

**method of payment form**

show: **BAKERY SHOWCASE 2024**  
 discount price deadline: **APRIL 12, 2024**

exhibitor information	
booth #:	company:
street:	
city:	prov/state: postal code:
phone #:	fax #:
email address: NEEDED FOR RECEIPT	
contact name:	

credit card authorization
card type: <input type="checkbox"/> VISA <input type="checkbox"/> MASTERCARD <input type="checkbox"/> AMEX
card #:
expiry date:
cardholder name:
cardholder signature:
<input type="checkbox"/> cheque attached (payable to BES Inc.)

**ALL ORDERS MUST BE PREPAID IN FULL.**  
 Orders cannot be delivered until payment is received

**PAYMENT/CANCELLATION POLICY** – Charges are for rental of items only. All items remain the property of BES, unless noted. All orders received after the stated deadline date, will be processed at the show price. Exhibitor is responsible for the care of all items for the duration of the event. Any discrepancies must be settled before show closing. Note that preparations for shows and events take place well ahead of time of delivery, hence, orders cancelled up to 7 days prior to show opening may be eligible for a 50% refund. Orders cancelled less than 7 days before opening may be eligible for up to a 25% refund depending on the nature of the order and the work performed. No refunds on equipment once it has been delivered to the booth.

**RATES**

Shipments are accepted in the warehouse Monday to Friday between 8:00 a.m. and 4:00 p.m.	SHIPMENTS RECEIVED ON OR BEFORE DEADLINE DATE		SHIPMENTS RECEIVED AFTER DEADLINE DATE		
	PRICE PER CWT				
	CRATED	UNCRATED		CRATED	UNCRATED
	\$90.00	\$105.00		\$100.00	\$115.00
<b>MINIMUM CHARGE</b>	The minimum charge applies to each shipment received.			<b>\$190.00</b>	

shipments are accepted from: **APRIL 1, 2024**  
 no shipments accepted in advance warehouse on or after: **APRIL 30, 2024**

**ADVANCE WAREHOUSING**

(when recording weight, round down to the nearest 100 lbs or minimum charge)

**POST-SHOW WAREHOUSING**

(when recording weight, round down to the nearest 100 lbs or minimum charge)

**CRATED/UNSKIDDED SHIPMENT**

$\frac{\text{WEIGHT (LBS)}}{100} = \text{CWT}$ $= \frac{\text{CWT}}{\text{CWT}} \times \text{Rate}$ $= \text{ESTIMATED TOTAL}$	$\frac{\text{WEIGHT (LBS)}}{100} = \text{CWT}$ $= \frac{\text{CWT}}{\text{CWT}} \times \text{Rate}$ $= \text{ESTIMATED TOTAL}$
--	--

**CRATED/UNSKIDDED SHIPMENT**

$\frac{\text{WEIGHT (LBS)}}{100} = \text{CWT}$ $= \frac{\text{CWT}}{\text{CWT}} \times \text{Rate}$ $= \text{ESTIMATED TOTAL}$	$\frac{\text{WEIGHT (LBS)}}{100} = \text{CWT}$ $= \frac{\text{CWT}}{\text{CWT}} \times \text{Rate}$ $= \text{ESTIMATED TOTAL}$
--	--

All shipments will be weighed upon receiving for verification.

4 advance/post-show warehousing

**\*\*Please use these shipping labels for freight being shipped to our warehouse.\*\***

**BAKERY SHOWCASE 2024**

**FROM**

---

---

---

**TO**

**Boneyard Event Services**  
7-4060 Ridgeway Drive  
Mississauga ON L5L 5X9

  
boneyard event services

**# OF PIECES**

\_\_\_\_\_ **OF** \_\_\_\_\_

**ADVANCE WAREHOUSE**

**BAKERY SHOWCASE 2024**

**FROM**

---

---

---

**TO**

**Boneyard Event Services**  
7-4060 Ridgeway Drive  
Mississauga ON L5L 5X9

  
boneyard event services

**# OF PIECES**

\_\_\_\_\_ **OF** \_\_\_\_\_

**ADVANCE WAREHOUSE**

**BAKERY SHOWCASE 2024**

**FROM**

---

---

---

**TO**

**Boneyard Event Services**  
7-4060 Ridgeway Drive  
Mississauga ON L5L 5X9

  
boneyard event services

**# OF PIECES**

\_\_\_\_\_ **OF** \_\_\_\_\_

**ADVANCE WAREHOUSE**

**BAKERY SHOWCASE 2024**

**FROM**

---

---

---

**TO**

**Boneyard Event Services**  
7-4060 Ridgeway Drive  
Mississauga ON L5L 5X9

  
boneyard event services

**# OF PIECES**

\_\_\_\_\_ **OF** \_\_\_\_\_

**ADVANCE WAREHOUSE**

**5 shipping labels**

show: **BAKERY SHOWCASE 2024**  
 discount price deadline: **APRIL 12, 2024**

exhibitor information	
booth #:	company:
street:	
city:	prov/state: postal code:
phone #:	fax #:
email address: NEEDED FOR RECEIPT	
contact name:	

credit card authorization
card type: <input type="checkbox"/> VISA <input type="checkbox"/> MASTERCARD <input type="checkbox"/> AMEX
card #:
expiry date:
cardholder name:
cardholder signature:
<input type="checkbox"/> cheque attached (payable to BES Inc.)

**LABOUR REQUESTS REQUIRE A CREDIT CARD ON FILE TO PROCESS LABOUR TIME POST SHOW.**  
 Orders cannot be delivered until credit card information is received

RATES			
REGULAR TIME	Mon - Sun	All Hours	\$ 90.00/hour/man
We do not charge overtime rates. Event work happens outside regular hours. We get that.			

- Labour rates are charged per labourer per hour in half hour increments.
- A minimum charge of one hour per labourer.
- BES INC. supervision rate, add 25% to the total labour cost.

INSTALLATION LABOUR	DISMANTLE LABOUR
**Exhibitor must report to BES INC. Service Desk to receive labour**	
Date Required _____ <input type="checkbox"/> AM Start Time Required _____ <input type="checkbox"/> PM  $\frac{\text{\# of people required}}{\text{}} \times \frac{\text{Hours per person}}{\text{}} = \frac{\text{Total Hours}}{\text{}} \times \frac{\text{Rate}}{\text{}} = \text{TOTAL}$	Date Required _____ <input type="checkbox"/> AM Start Time Required _____ <input type="checkbox"/> PM  $\frac{\text{\# of people required}}{\text{\# of people required}} \times \frac{\text{Hours per person}}{\text{Hours per person}} = \frac{\text{Total Hours}}{\text{Total Hours}} \times \frac{\text{Rate}}{\text{Rate}} = \text{TOTAL}$

SUPERVISION (NOTE: If Exhibitor is supervising labour, the Exhibitor must check labour in and out at the BES INC. Service Desk)			
<input type="checkbox"/> Exhibitor Supervised <small>*Exhibitor must be present to supervise</small>	<input type="checkbox"/> BES INC. Supervised <small>*Exhibitor does not need be present</small>	<input type="checkbox"/> Exhibitor Supervised <small>*Exhibitor must be present to supervise</small>	<input type="checkbox"/> BES INC. Supervised <small>*Exhibitor does not need be present</small>
Exhibitor Contact Name _____ \$ _____ Add 25%		Exhibitor Contact Name _____ \$ _____ Add 25%	

DELIVERY INFORMATION	
Carrier _____ <input type="checkbox"/> AM <input type="checkbox"/> PM	Carrier _____ <input type="checkbox"/> AM <input type="checkbox"/> PM
Delivery Date _____ Delivery Time _____	Delivery Date _____ Delivery Time _____

EXHIBIT INFORMATION
Set-up drawings/photos required: <input type="checkbox"/> YES <input type="checkbox"/> NO
Set-up drawings/photos attached: <input type="checkbox"/> YES <input type="checkbox"/> NO

<b>SUBTOTAL</b>	
<b>13% HST</b>	
<b>TOTAL</b>	

**6 exhibit labour**



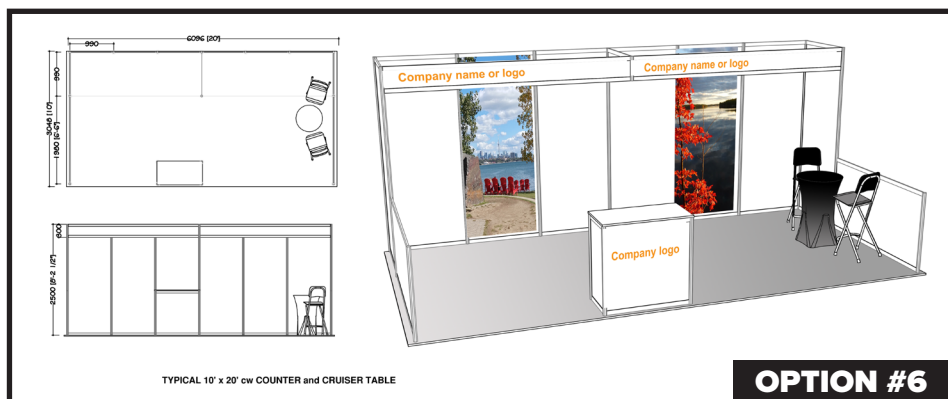
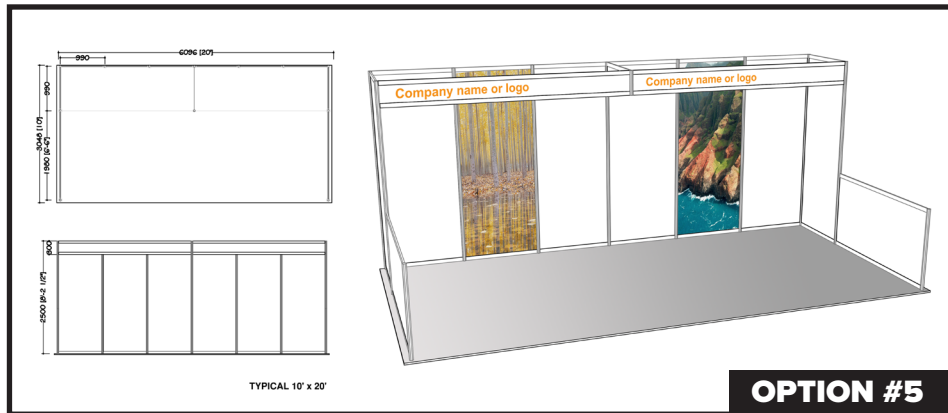
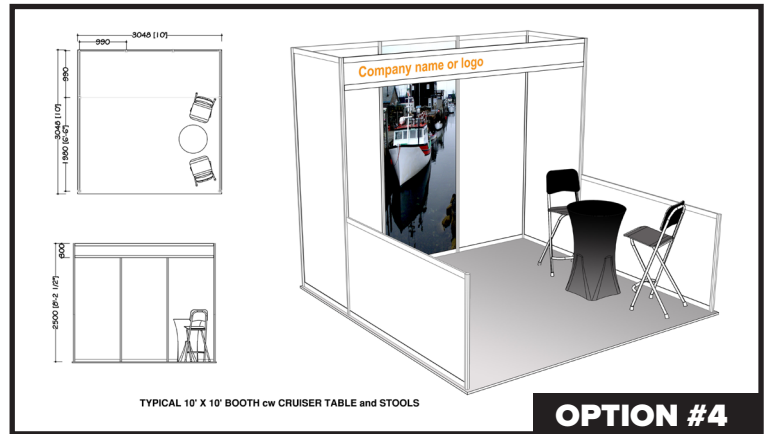
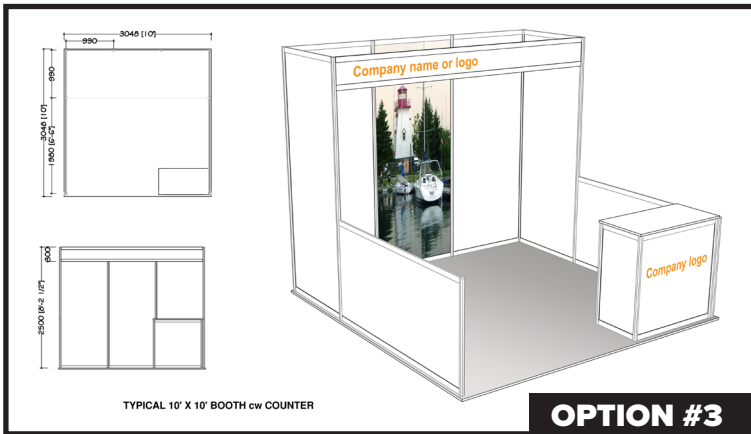
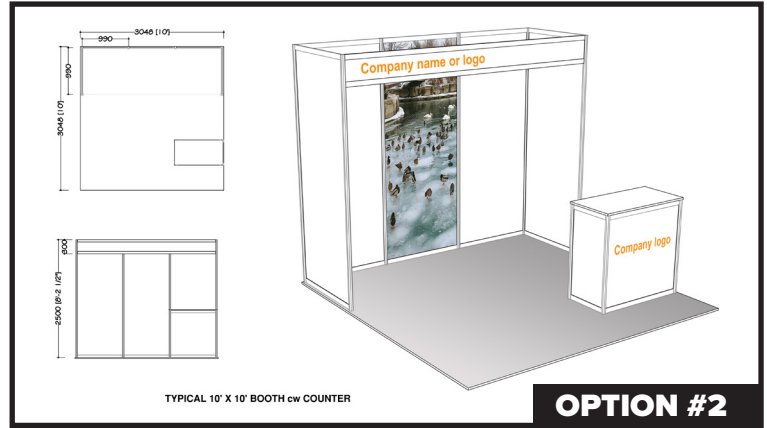
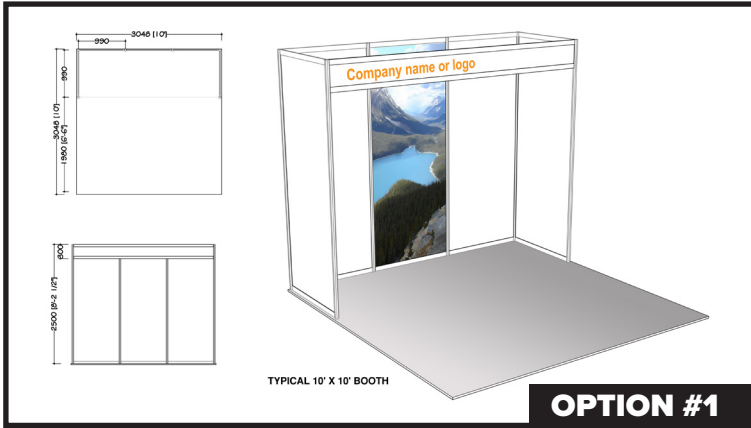

**\*\* ELECTRICAL, LIGHTING AND FULL HEIGHT GRAPHICS ARE NOT INCLUDED \*\***





**OPTION #1**



**OPTION #2**



**OPTION #3**



**OPTION #4**



**OPTION #5**



**OPTION #6**

**custom exhibit samples**

*\*\*These are samples of our capabilities. If you are interested in a custom exhibit or custom exhibit components, please contact us at 833.237.7469 ext. 701 to discuss your individual needs. \*\**



show: **BAKERY SHOWCASE 2024**  
 discount price deadline: **APRIL 12, 2024**

exhibitor information	
booth #:	company:
street:	
city:	prov/state: postal code:
phone #:	fax #:
email address: NEEDED FOR RECEIPT	
contact name:	

credit card authorization
card type: <input type="checkbox"/> VISA <input type="checkbox"/> MASTERCARD <input type="checkbox"/> AMEX
card #:
expiry date:
cardholder name:
cardholder signature:
<input type="checkbox"/> cheque attached (payable to BES Inc.)

**ALL ORDERS MUST BE PREPAID IN FULL.**  
 Orders cannot be delivered until payment is received

**PAYMENT/CANCELLATION POLICY** – Charges are for rental of items only. All items remain the property of BES, unless noted. All orders received after the stated deadline date, will be processed at the show price. Exhibitor is responsible for the care of all items for the duration of the event. Any discrepancies must be settled before show closing. Note that preparations for shows and events take place well ahead of time of delivery, hence, orders cancelled up to 7 days prior to show opening may be eligible for a 50% refund. Orders cancelled less than 7 days before opening may be eligible for up to a 25% refund depending on the nature of the order and the work performed. No refunds on equipment once it has been delivered to the booth.

**ALL PACKAGES INCLUDE**

Installation & Dismantling • Choice of Panel Colour • Choice of Carpet Colour • Company Identification Sign

**EXHIBIT PACKAGES** (Electrical, lighting & graphic panel requirements are **NOT** included)

QTY	DESCRIPTION	DISCOUNT PRICE	SHOW PRICE	TOTAL
	OPTION #1 – 10'x10'	\$ 850.00	\$ 1,200.00	\$
	OPTION #2 – 10'x10'	\$ 1,385.00	\$ 1,800.00	\$
	OPTION #3 – 10'x10'	\$ 1,385.00	\$ 1,800.00	\$
	OPTION #4 – 10'x10'	\$ 1,605.00	\$ 2,400.00	\$
	OPTION #5 – 10'x20'	\$ 2,100.00	\$ 2,750.00	\$
	OPTION #6 – 10'x20'	\$ 2,770.00	\$ 3,740.00	\$

**PLEASE COMPLETE THE FOLLOWING:**

**CARPET COLOUR**

Red  Blue  Grey  Black

**PANEL COLOUR**

White  Black

**ADD GRAPHICS TO CUSTOMIZE YOUR BOOTH!**

QTY	DESCRIPTION	DISCOUNT PRICE	SHOW PRICE	TOTAL
	Add company logo to ID sign	\$ 75.00	\$ 120.00	\$
	Full height graphic panel	\$ 345.00	\$ 520.00	\$
	Sidewall low rail panel graphic	\$ 170.00	\$ 250.00	\$
	Counter Graphics - Front	\$ 120.00	\$ 180.00	\$

\* Graphic prices are based on print ready files. A BES INC. representative will contact you with file submission details.  
 \* Design services can be quoted if required.

**IDENTIFICATION SIGN TO READ:**

\_\_\_\_\_

\_\_\_\_\_

\_\_\_\_\_

\_\_\_\_\_

<b>SUBTOTAL</b>	
<b>13% HST</b>	
<b>TOTAL</b>	

show: **BAKERY SHOWCASE 2024**  
 discount price deadline: **APRIL 12, 2024**

exhibitor information	
booth #:	company:
street:	
city:	prov/state: postal code:
phone #:	fax #:
email address: NEEDED FOR RECEIPT	
contact name:	

credit card authorization
card type: <input type="checkbox"/> VISA <input type="checkbox"/> MASTERCARD <input type="checkbox"/> AMEX
card #:
expiry date:
cardholder name:
cardholder signature:
<input type="checkbox"/> cheque attached (payable to BES Inc.)

**ALL ORDERS MUST BE PREPAID IN FULL.**  
 Orders cannot be delivered until payment is received

**PAYMENT/CANCELLATION POLICY** – Charges are for rental of items only. All items remain the property of BES, unless noted. All orders received after the stated deadline date, will be processed at the show price. Exhibitor is responsible for the care of all items for the duration of the event. Any discrepancies must be settled before show closing. Note that preparations for shows and events take place well ahead of time of delivery, hence, orders cancelled up to 7 days prior to show opening may be eligible for a 50% refund. Orders cancelled less than 7 days before opening may be eligible for up to a 25% refund depending on the nature of the order and the work performed. No refunds on equipment once it has been delivered to the booth.

CARPETS				
QTY.	DESCRIPTION	DISCOUNT PRICE	SHOW PRICE	TOTAL
	_____ ft x _____ ft <b>STANDARD CARPET</b>	\$ 1.70 / sq. ft.	\$ 2.30 / sq. ft.	\$
SELECT COLOUR: <input type="checkbox"/> Red <input type="checkbox"/> Blue <input type="checkbox"/> Grey <input type="checkbox"/> Black <input type="checkbox"/> Green				
	_____ ft x _____ ft <b>PREMIUM CARPET</b>	\$ 2.05 / sq. ft.	\$ 3.05 / sq. ft.	\$
SELECT COLOUR: <input type="checkbox"/> Red <input type="checkbox"/> Blue <input type="checkbox"/> Grey <input type="checkbox"/> Black <input type="checkbox"/> Green				
	Specialty Carpet - additional colours possible if ordered earlier	<b>CALL FOR QUOTE</b>		
	Underpadding	\$ 0.90 / sq. ft.	\$ 1.30 / sq. ft.	\$
	Plastic Covering	\$ 0.55 / sq. ft.	\$ 0.75 / sq. ft.	\$

<b>SUBTOTAL</b>	
<b>13% HST</b>	
<b>TOTAL</b>	

show: **BAKERY SHOWCASE 2024**  
 discount price deadline: **APRIL 12, 2024**

exhibitor information		credit card authorization	
booth #:	company:	card type:	<input type="checkbox"/> VISA <input type="checkbox"/> MASTERCARD <input type="checkbox"/> AMEX
street:		card #:	
city:	prov/state:	expiry date:	
postal code:		cardholder name:	
phone #:	fax #:	cardholder signature:	
email address: NEEDED FOR RECEIPT		<input type="checkbox"/> cheque attached (payable to BES Inc.)	
contact name:			

**ALL ORDERS MUST BE PREPAID IN FULL.**  
 Orders cannot be delivered until payment is received

**PAYMENT/CANCELLATION POLICY** – Charges are for rental of items only. All items remain the property of BES, unless noted. All orders received after the stated deadline date, will be processed at the show price. Exhibitor is responsible for the care of all items for the duration of the event. Any discrepancies must be settled before show closing. Note that preparations for shows and events take place well ahead of time of delivery, hence, orders cancelled up to 7 days prior to show opening may be eligible for a 50% refund. Orders cancelled less than 7 days before opening may be eligible for up to a 25% refund depending on the nature of the order and the work performed. No refunds on equipment once it has been delivered to the booth.

**SKIRTED TABLES – 30” HIGH** \*skirted tables include white vinyl top & pleated skirt on three sides. Fourth side can be skirted as an addition.

QTY	DESCRIPTION	DISCOUNT PRICE	SHOW PRICE	TOTAL
	4'L x 24"W x30"H	\$ 65.00	\$ 85.00	\$
	6'L x 24"W x30"H	\$ 80.00	\$ 97.00	\$
	8'L x 24"W x30"H	\$ 98.00	\$ 115.00	\$
	4th Side Skirted	\$ 25.00	\$ 35.00	\$

SELECT COLOUR:  Red  Blue  Black  Green  Burgundy  White

**SKIRTED TABLES – 42” HIGH** \*skirted tables include white vinyl top & pleated skirt on three sides. Fourth side can be skirted as an addition.

	4'L x 24"W x42"H	\$ 75.00	\$ 90.00	\$
	6'L x 24"W x42"H	\$ 90.00	\$ 105.00	\$
	8'L x 24"W x42"H	\$ 110.00	\$ 120.00	\$
	4th Side Skirted	\$ 35.00	\$ 45.00	\$

SELECT COLOUR:  Red  Blue  Black  Green  Burgundy  White

**BARE TABLES – 30” HIGH** \*bare tables include white vinyl top.

	4'L x 24"W x30"H	\$ 45.00	\$ 55.00	\$
	6'L x 24"W x30"H	\$ 50.00	\$ 60.00	\$
	8'L x 24"W x30"H	\$ 60.00	\$ 70.00	\$

**BARE TABLES – 42” HIGH** \*bare tables include white vinyl top.

	4'L x 24"W x42"H	\$ 45.00	\$ 55.00	\$
	6'L x 24"W x42"H	\$ 50.00	\$ 60.00	\$
	8'L x 24"W x42"H	\$ 60.00	\$ 70.00	\$

**DRAPE**

QTY	DESCRIPTION	DISCOUNT PRICE	SHOW PRICE	TOTAL
	3' High	\$ 7.00 /Linear Foot	\$ 8.00 /Linear Foot	\$
	8' High	\$ 9.00 /Linear Foot	\$ 10.00 /Linear Foot	\$
	12' High	\$ 12.00 /Linear Foot	\$ 15.00 /Linear Foot	\$

SELECT COLOUR:  Red  Blue  Gold  Black  Green  White

<b>SUBTOTAL</b>	
<b>13% HST</b>	
<b>TOTAL</b>	

**11 skirted tables & drape**



**cruiser tables**



Bare  
30" D x 42" H



with spandex cover  
30" D x 42" H



24" D x 42" H

**café tables**



Bare  
30" D x 30" H



with spandex cover  
White or Black  
30" D x 30" H



48" D x 30" H

**coffee & end tables**



Black Top  
24" x 48"



Chrome & Glass  
24" x 48"



Chrome & Glass  
24" x 24"



White, basic  
24" x 48"

show: **BAKERY SHOWCASE 2024**  
 discount price deadline: **APRIL 12, 2024**

exhibitor information	
booth #:	company:
street:	
city:	prov/state: postal code:
phone #:	fax #:
email address: NEEDED FOR RECEIPT	
contact name:	

credit card authorization
card type: <input type="checkbox"/> VISA <input type="checkbox"/> MASTERCARD <input type="checkbox"/> AMEX
card #:
expiry date:
cardholder name:
cardholder signature:
<input type="checkbox"/> cheque attached (payable to BES Inc.)

**ALL ORDERS MUST BE PREPAID IN FULL.**  
 Orders cannot be delivered until payment is received

**PAYMENT/CANCELLATION POLICY** – Charges are for rental of items only. All items remain the property of BES, unless noted. All orders received after the stated deadline date, will be processed at the show price. Exhibitor is responsible for the care of all items for the duration of the event. Any discrepancies must be settled before show closing. Note that preparations for shows and events take place well ahead of time of delivery, hence, orders cancelled up to 7 days prior to show opening may be eligible for a 50% refund. Orders cancelled less than 7 days before opening may be eligible for up to a 25% refund depending on the nature of the order and the work performed. No refunds on equipment once it has been delivered to the booth.

**CRUISER TABLES**

QTY	DESCRIPTION	DISCOUNT PRICE	SHOW PRICE	TOTAL
	Cruiser Table, bare – 30" D	\$ 85.00	\$ 120.00	\$
	30" Cruiser Table with Spandex Cover <input type="checkbox"/> White <input type="checkbox"/> Black <input type="checkbox"/> Navy <input type="checkbox"/> Green <input type="checkbox"/> Orange <input type="checkbox"/> Red	\$ 120.00	\$ 157.00	\$
	Brushed Aluminum Cruiser Table	\$ 140.00	\$ 175.00	\$

**CAFE & MEETING TABLES**

QTY	DESCRIPTION	DISCOUNT PRICE	SHOW PRICE	TOTAL
	Cafe Table – Bare	\$ 70.00	\$ 105.00	\$
	Cafe Table with Spandex Cover <input type="checkbox"/> White <input type="checkbox"/> Black	\$ 105.00	\$ 135.00	\$
	Meeting Table	\$ 130.00	\$ 192.00	\$

**COFFEE & END TABLES**

	Chrome & Glass Coffee Table – 24" x 48"	\$ 110.00	\$ 160.00	\$
	Chrome & Glass End Table – 24" x 24"	\$ 90.00	\$ 135.00	\$
	Coffee Table, black top	\$ 110.00	\$ 160.00	\$
	White Coffee Table, basic	\$ 60.00	\$ 75.00	\$

<b>SUBTOTAL</b>	
<b>13% HST</b>	
<b>TOTAL</b>	

**chairs**



**SIDE CHAIR**

Black fabric



**STENO CHAIR**

Black fabric



**FOLDING CHAIR**

Black



**SIDE CHAIR**

Black

**stools**



**LOW BACK STOOL**

White, Black  
Leather



**FOLDING STOOL**

Black



**GAS LIFT STOOL**

Black, White

**barcelona line**



**SOFA - 3 SEATER**

Black, White



**SOFA - 2 SEATER**

Black, White



**CHAIR & FOOT STOOL**

Black, White



show: **BAKERY SHOWCASE 2024**  
 discount price deadline: **APRIL 12, 2024**

exhibitor information	
booth #:	company:
street:	
city:	prov/state: postal code:
phone #:	fax #:
email address: NEEDED FOR RECEIPT	
contact name:	

credit card authorization
card type: <input type="checkbox"/> VISA <input type="checkbox"/> MASTERCARD <input type="checkbox"/> AMEX
card #:
expiry date:
cardholder name:
cardholder signature:
<input type="checkbox"/> cheque attached (payable to BES Inc.)

**ALL ORDERS MUST BE PREPAID IN FULL.**  
 Orders cannot be delivered until payment is received

**PAYMENT/CANCELLATION POLICY** – Charges are for rental of items only. All items remain the property of BES, unless noted. All orders received after the stated deadline date, will be processed at the show price. Exhibitor is responsible for the care of all items for the duration of the event. Any discrepancies must be settled before show closing. Note that preparations for shows and events take place well ahead of time of delivery, hence, orders cancelled up to 7 days prior to show opening may be eligible for a 50% refund. Orders cancelled less than 7 days before opening may be eligible for up to a 25% refund depending on the nature of the order and the work performed. No refunds on equipment once it has been delivered to the booth.

CHAIRS				
QTY	DESCRIPTION	DISCOUNT PRICE	SHOW PRICE	TOTAL
	Side Chair, Black Fabric	\$ 39.00	\$ 59.00	\$
	Steno Chair, Black Fabric	\$ 65.00	\$ 94.00	\$
	Folding Chair, Black	\$ 15.00	\$ 19.00	\$
	Plastic Side Chair, Basic	\$ 27.00	\$ 45.00	\$

STOOLS				
QTY	DESCRIPTION	DISCOUNT PRICE	SHOW PRICE	TOTAL
	Low Back Black Leather Bar Stool	\$ 99.00	\$ 145.00	\$
	Low Back White Leather Bar Stool	\$ 99.00	\$ 145.00	\$
	Folding Stool	\$ 52.00	\$ 65.00	\$
	Gas Lift Stool – White Seat	\$ 99.00	\$ 152.00	\$
	Gas Lift Stool – Black Seat	\$ 99.00	\$ 152.00	\$

BARCELONA LINE				
QTY	DESCRIPTION	DISCOUNT PRICE	SHOW PRICE	TOTAL
	Barcelona black sofa, 3 seater	\$ 400.00	\$ 520.00	\$
	Barcelona white sofa, 3 seater	\$ 400.00	\$ 520.00	\$
	Barcelona black sofa, 2 seater	\$ 295.00	\$ 370.00	\$
	Barcelona white sofa, 2 seater	\$ 295.00	\$ 370.00	\$
	Barcelona black single chair	\$ 210.00	\$ 290.00	\$
	Barcelona white single chair	\$ 210.00	\$ 290.00	\$
	Barcelona black foot stool	\$ 150.00	\$ 210.00	\$
	Barcelona white foot stool	\$ 150.00	\$ 210.00	\$

<b>SUBTOTAL</b>	
<b>13% HST</b>	
<b>TOTAL</b>	

## miscellaneous items



**BALLOT DRUM**

Brass



**BAR FRIDGE**

White or Black



**BAG HOLDER**



**COAT TREE**



**EASEL**



**GARMENT RACK**

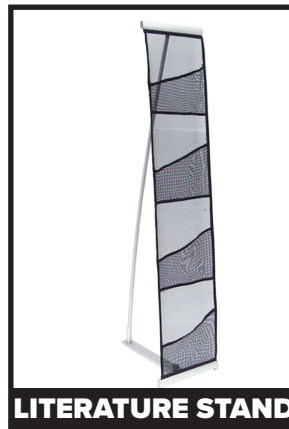

**LITERATURE STAND**



**STANCHION**

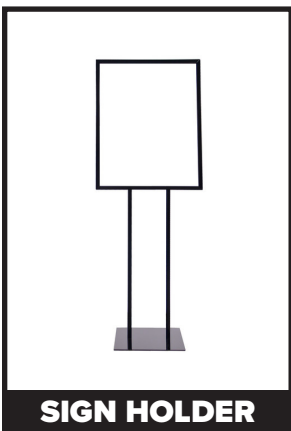

**SIGN HOLDER**



**WASTEBASKET**

show: **BAKERY SHOWCASE 2024**  
 discount price deadline: **APRIL 12, 2024**

exhibitor information	
booth #:	company:
street:	
city:	prov/state: postal code:
phone #:	fax #:
email address: NEEDED FOR RECEIPT	
contact name:	

credit card authorization
card type: <input type="checkbox"/> VISA <input type="checkbox"/> MASTERCARD <input type="checkbox"/> AMEX
card #:
expiry date:
cardholder name:
cardholder signature:
<input type="checkbox"/> cheque attached (payable to BES Inc.)

**ALL ORDERS MUST BE PREPAID IN FULL.**  
 Orders cannot be delivered until payment is received

**PAYMENT/CANCELLATION POLICY** – Charges are for rental of items only. All items remain the property of BES, unless noted. All orders received after the stated deadline date, will be processed at the show price. Exhibitor is responsible for the care of all items for the duration of the event. Any discrepancies must be settled before show closing. Note that preparations for shows and events take place well ahead of time of delivery, hence, orders cancelled up to 7 days prior to show opening may be eligible for a 50% refund. Orders cancelled less than 7 days before opening may be eligible for up to a 25% refund depending on the nature of the order and the work performed. No refunds on equipment once it has been delivered to the booth.

MISCELLANEOUS ITEMS				
QTY	DESCRIPTION	DISCOUNT PRICE	SHOW PRICE	TOTAL
	Ballot Box, Brass – 21" square x 36"H	\$ 115.00	\$ 180.00	\$
	Bar Fridge <b>**NOTE - does NOT include electrical**</b> <input type="checkbox"/> White <input type="checkbox"/> Black	\$ 185.00	\$ 245.00	\$
	Bag Holder	\$ 95.00	\$ 145.00	\$
	Coat Tree	\$ 30.00	\$ 50.00	\$
	Easel	\$ 30.00	\$ 45.00	\$
	Garment Rack, rolling	\$ 60.00	\$ 90.00	\$
	Lit Stand - with 4 pockets	\$ 45.00	\$ 65.00	\$
	Retractable Stanchion, with black strap (each)	\$ 50.00	\$ 80.00	\$
	Sign Holder	\$ 35.00	\$ 50.00	\$
	Wastebasket	\$ 10.00	\$ 15.00	\$

<b>SUBTOTAL</b>	
<b>13% HST</b>	
<b>TOTAL</b>	



## counters & plinths

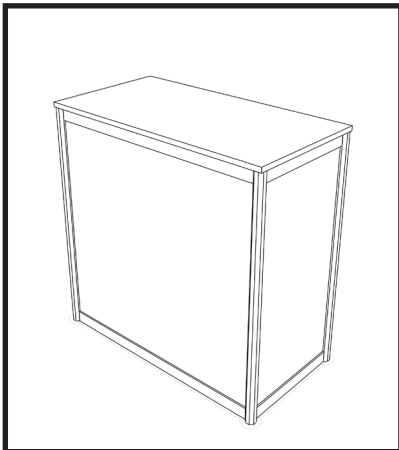

**STORAGE COUNTER**

40" W x 20" D x 40" H

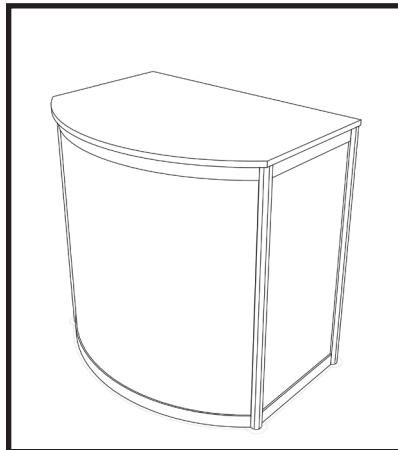

**CURVED COUNTER**

40" W x 20" D x 40" H

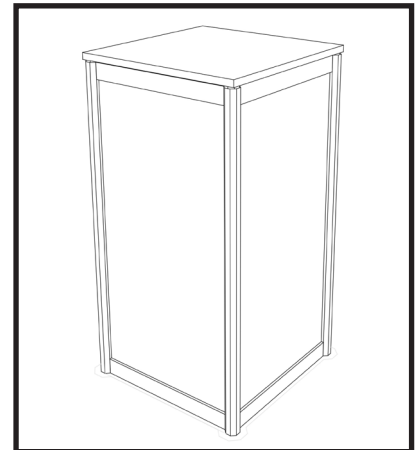

**PLINTH**

20" W x 20" D x 40" H

\*\*can be customized\*\*

## showcases

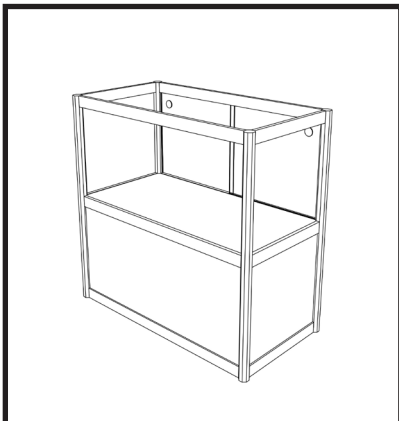

**COUNTER SHOWCASE  
1/2 VIEW**

40" W x 20" D x 40" H

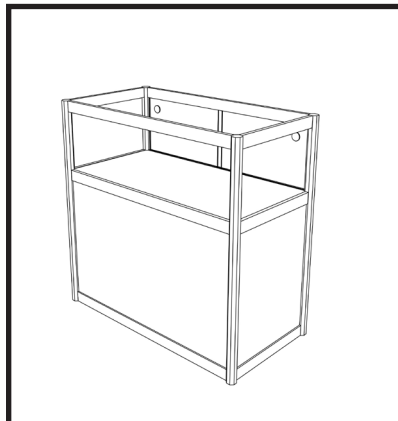

**COUNTER SHOWCASE  
1/3 VIEW**

40" W x 20" D x 40" H



**FULL VIEW TOWER  
SHOWCASE**

40" W X 20" D X 96" H

show: **BAKERY SHOWCASE 2024**  
 discount price deadline: **APRIL 12, 2024**

exhibitor information	
booth #:	company:
street:	
city:	prov/state: postal code:
phone #:	fax #:
email address: NEEDED FOR RECEIPT	
contact name:	

credit card authorization
card type: <input type="checkbox"/> VISA <input type="checkbox"/> MASTERCARD <input type="checkbox"/> AMEX
card #:
expiry date:
cardholder name:
cardholder signature:
<input type="checkbox"/> cheque attached (payable to BES Inc.)

**ALL ORDERS MUST BE PREPAID IN FULL.**  
 Orders cannot be delivered until payment is received

**PAYMENT/CANCELLATION POLICY** – Charges are for rental of items only. All items remain the property of BES, unless noted. All orders received after the stated deadline date, will be processed at the show price. Exhibitor is responsible for the care of all items for the duration of the event. Any discrepancies must be settled before show closing. Note that preparations for shows and events take place well ahead of time of delivery, hence, orders cancelled up to 7 days prior to show opening may be eligible for a 50% refund. Orders cancelled less than 7 days before opening may be eligible for up to a 25% refund depending on the nature of the order and the work performed. No refunds on equipment once it has been delivered to the booth.

COUNTERS & PLINTHS				
QTY	DESCRIPTION	DISCOUNT PRICE	SHOW PRICE	TOTAL
	Counter Storage Unit <input type="checkbox"/> Black <input type="checkbox"/> White	\$ 155.00	\$ 230.00	\$
	Curved Storage Counter <input type="checkbox"/> Black <input type="checkbox"/> White	\$ 295.00	\$ 420.00	\$
	20" Square Plinth <input type="checkbox"/> Black <input type="checkbox"/> White	\$ 120.00	\$ 180.00	\$

SHOWCASES				
QTY	DESCRIPTION	DISCOUNT PRICE	SHOW PRICE	TOTAL
	Glass Display Case (1/3 view)	\$ 325.00	\$ 440.00	\$
	Glass Display Case (full view)	\$ 375.00	\$ 510.00	\$
	Tower Showcase	\$ 368.00	\$ 525.00	\$

<b>SUBTOTAL</b>	
<b>13% HST</b>	
<b>TOTAL</b>	

show: **BAKERY SHOWCASE 2024**  
 discount price deadline: **APRIL 5, 2024**

**exhibitor information**

booth #:	company:
street:	
city:	prov/state: postal code:
phone #:	fax #:
email address: NEEDED FOR RECEIPT	
contact name:	

**credit card authorization**

card type:  VISA  MASTERCARD  AMEX

card #:

expiry date:

cardholder name:

cardholder signature:

cheque attached (payable to BES Inc.)

**ALL ORDERS MUST BE PREPAID IN FULL.**  
 Orders cannot be delivered until payment is received

**PAYMENT/CANCELLATION POLICY** – Charges are for rental of items only. All items remain the property of BES, unless noted. All orders received after the stated deadline date, will be processed at the show price. Exhibitor is responsible for the care of all items for the duration of the event. Any discrepancies must be settled before show closing. Note that preparations for shows and events take place well ahead of time of delivery, hence, orders cancelled up to 7 days prior to show opening may be eligible for a 50% refund. Orders cancelled less than 7 days before opening may be eligible for up to a 25% refund depending on the nature of the order and the work performed. No refunds on equipment once it has been delivered to the booth. Refunds are not eligible on signage already produced.

**BANNERS (SINGLE-SIDED)**

QTY	DESCRIPTION	DISCOUNT PRICE	SHOW PRICE	TOTAL
	24" x 48"	\$ 130.00	\$ 200.00	\$
	24" x 72"	\$ 200.00	\$ 300.00	\$
	24" x 96"	\$ 270.00	\$ 400.00	\$
	36" x 72"	\$ 300.00	\$ 450.00	\$

QTY	DESCRIPTION	DISCOUNT PRICE	SHOW PRICE	TOTAL
	36" x 96"	\$ 400.00	\$ 600.00	\$
	36" x 120"	\$ 510.00	\$ 760.00	\$
	48" x 96"	\$ 540.00	\$ 810.00	\$
	48" x 120"	\$ 615.00	\$ 900.00	\$

**PLATFORM BASE BANNER STAND (SINGLE-SIDED)**

QTY	DESCRIPTION	DISCOUNT PRICE	SHOW PRICE	TOTAL
	33"W x 78"H Retractable Banner Stand with graphics	\$ 400.00	\$ 500.00	\$
	48"W x 78"H Retractable Banner Stand with graphics	\$ 520.00	\$ 650.00	\$

• Includes black canvas carrying case      • based on client supplied graphics      • double-sided available

**SIGNS (SINGLE-SIDED)**

**PVC** (suitable for multiple uses)

QTY	DESCRIPTION	DISCOUNT PRICE	SHOW PRICE	TOTAL
	8" x 44"	\$ 54.00	\$ 80.00	\$
	14" x 22"	\$ 57.00	\$ 86.00	\$
	22" x 28"	\$ 78.00	\$ 117.00	\$
	24" x 32"	\$ 94.00	\$ 149.00	\$
	36" x 48"	\$ 183.00	\$ 239.00	\$

**SIGNS (SINGLE-SIDED)**

**ULTRA BOARD**

QTY	DESCRIPTION	DISCOUNT PRICE	SHOW PRICE	TOTAL
	8" x 44"	\$ 43.00	\$ 65.00	\$
	14" x 22"	\$ 49.00	\$ 71.00	\$
	22" x 28"	\$ 65.00	\$ 97.00	\$
	24" x 32"	\$ 77.00	\$ 115.00	\$
	36" x 48"	\$ 143.00	\$ 255.00	\$

<b>SUBTOTAL</b>	
<b>13% HST</b>	
<b>TOTAL</b>	



7-4060 Ridgeway Drive, Mississauga ON L5L 5X9  
 t: 833.237.7469 | f: 866.526.4869 | e:info@bes.show  
 www.bes.show

**PICK UP ADDRESS**

COMPANY NAME: \_\_\_\_\_ CONTACT NAME: \_\_\_\_\_  
 SHOW NAME: \_\_\_\_\_ CONTACT PHONE #: \_\_\_\_\_  
 ADDRESS: \_\_\_\_\_

**DELIVERY ADDRESS**

COMPANY NAME: \_\_\_\_\_ BOOTH #: \_\_\_\_\_  
 SHOW NAME: \_\_\_\_\_  
 ADDRESS: \_\_\_\_\_  
 ON-SITE CONTACT: \_\_\_\_\_ CONTACT PHONE #: \_\_\_\_\_

WE REQUIRE CUSTOMS CLEARANCE

WE REQUIRE A RETURN SHIPMENT

**RETURN ADDRESS**

SAME AS PICK UP ADDRESS  
 COMPANY NAME: \_\_\_\_\_ CONTACT NAME: \_\_\_\_\_  
 SHOW NAME: \_\_\_\_\_  
 ADDRESS: \_\_\_\_\_

**BILLING ADDRESS**

COMPANY NAME: \_\_\_\_\_  
 CONTACT NAME: \_\_\_\_\_ CONTACT PHONE #: \_\_\_\_\_  
 ADDRESS: \_\_\_\_\_

**SHIPMENT DETAILS**

INITIAL PICK UP			RETURN PICK UP		
PICK UP DATE _____	TIME _____		PICK UP DATE _____	TIME _____	
Loading Dock Available: <input type="checkbox"/> YES <input type="checkbox"/> NO			Loading Dock Available: <input type="checkbox"/> YES <input type="checkbox"/> NO		
Tractor Trailer Accessible: <input type="checkbox"/> YES <input type="checkbox"/> NO			Tractor Trailer Accessible: <input type="checkbox"/> YES <input type="checkbox"/> NO		

TYPE	PIECES	DIMENSIONS (in.)			WEIGHT (LBS)
Cartons/Boxes	_____	L _____	W _____	H _____	_____
Crates/Fiber Case	_____	L _____	W _____	H _____	_____
Skid/Pallet	_____	L _____	W _____	H _____	_____
Carpet/Other	_____	L _____	W _____	H _____	_____
<b>TOTAL PIECES</b> _____					<b>TOTAL LBS</b> _____

Additional Services Required:  LIFT GATE  INSIDE PICKUP/DELIVERY

**TERMS & CONDITIONS**

This request is placed with the understanding that we hereby release Boneyard Event Services Inc. and/or agents from all liability for loss, damage and/or theft to our merchandise and property, no matter how caused, and we have insured all such properties being handled.  
 1 – Boneyard Logistics shall not be responsible to damage to uncrated materials, improperly packaged or concealed damage.  
 2 – Boneyard Logistics will not be responsible for any loss/damage/delay due to fire, acts of god, strikes or lock outs of any kind.  
 3 – Boneyard Logistics shall not be liable to any extent whatsoever for the actual, potential or assumed losses of profits or revenues, or for any collateral costs which may result from any loss or damage to any exhibition materials.  
 4 – Each exhibitor is responsible for declaring all hazardous materials, and to abide by Federal, Provincial and Local Laws.

I have read and agreed to the Terms and Conditions of this contract with BES INC.

NAME \_\_\_\_\_ SIGNATURE/AUTHORIZATION \_\_\_\_\_ DATE \_\_\_\_\_

transportation services 21